

# **LL-803ID2C**

## **DATA SHEET**

QC:

ENG:

Prepared By:

## Features

- ◆ High intensity
- ◆ 10mm diameter package
- ◆ Wide viewing angle
- ◆ General purpose leads
- ◆ Reliable and rugged

## Package Dimension:

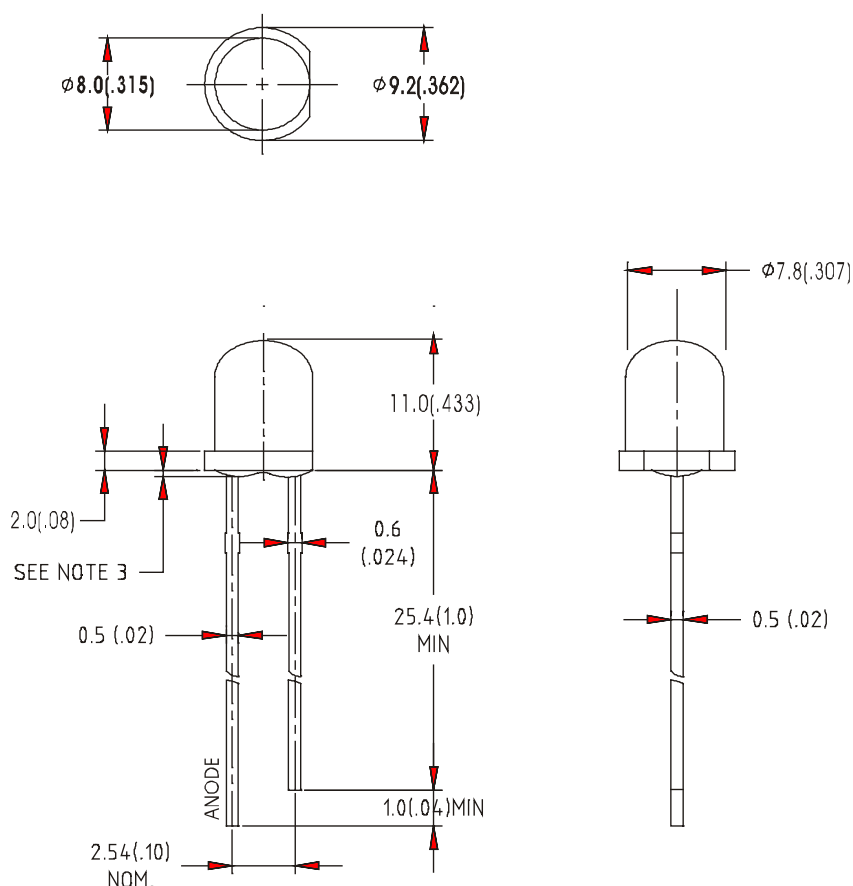

Part NO.	Lens Color	Source Color
LL-803ID2C	Red Diffused	Hi-Eff Red

### Notes:

1. All dimensions are in millimeters (inches).
2. Tolerance is  $\pm 0.25 (.010)$  mm unless otherwise noted.
3. Protruded resin under flange is 1.0mm(.04") max
4. Lead spacing is measured where the leads emerge from the package.
5. Specifications are subject to change without notice

**Absolute Maximum Ratings at Ta=25°C**

Parameter	MAX.	Unit
Power Dissipation	100	mW
Peak Forward Current (1/10 Duty Cycle, 0.1ms Pulse Width)	100	mA
Continuous Forward Current	40	mA
Derating Linear From 50°C	0.4	mA/°C
Reverse Voltage	5	V
Operating Temperature Range	-40°C to +80°C	
Storage Temperature Range	-40°C to +80°C	
Lead Soldering Temperature [4mm(.157") From Body]	260°C for 5 Seconds	

**Electrical Optical Characteristics at Ta=25°C**

Parameter	Symbol	Min.	Typ.	Max.	Unit	Test Condition
Luminous Intensity	I <sub>v</sub>	100	150	---	mcd	I <sub>F</sub> =20mA (Note 1)
Viewing Angle	2θ <sub>1/2</sub>	---	50	---	Deg	(Note 2)
Peak Emission Wavelength	λ <sub>p</sub>	---	630	---	nm	I <sub>F</sub> =20mA
Dominant Wavelength	λ <sub>d</sub>	---	631	---	nm	I <sub>F</sub> =20mA (Note 3)
Spectral Line Half-Width	Δλ	---	42	---	nm	I <sub>F</sub> =20mA
Forward Voltage	V <sub>F</sub>	---	2.0	2.8	V	I <sub>F</sub> =20mA
Reverse Current	I <sub>R</sub>	---	---	100	μA	V <sub>R</sub> =5V

**Note:**

1. Luminous intensity is measured with a light sensor and filter combination that approximates the CIE eye-response curve.
2. θ<sub>1/2</sub> is the off-axis angle at which the luminous intensity is half the axial luminous intensity.
3. The dominant wavelength (λ<sub>d</sub>) is derived from the CIE chromaticity diagram and represents the single wavelength which defines the color of the device.

**Typical Electrical / Optical Characteristics Curves**  
 (25°C Ambient Temperature Unless Otherwise Noted)

**Spectral Radiance (Peak @ 630nm)**

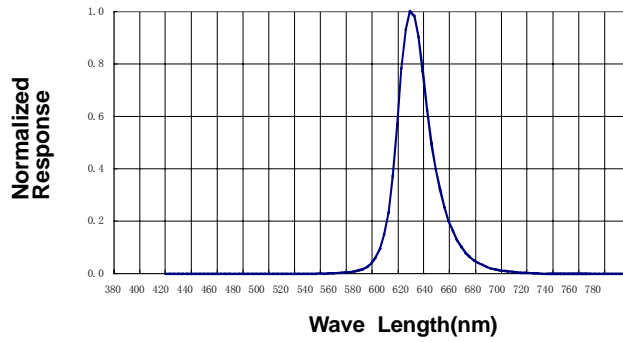

**Forward Current vs Forward Voltage**

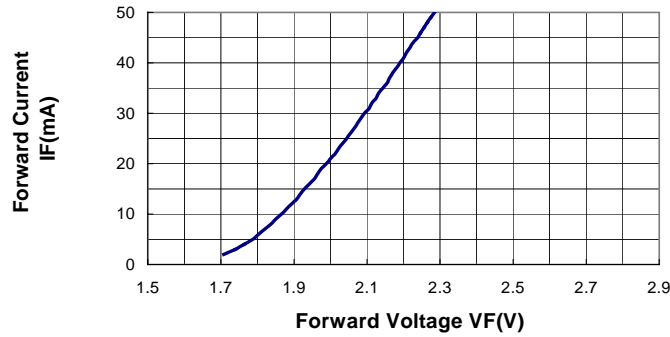

**Relative Luminous Intensity vs Forward Current**

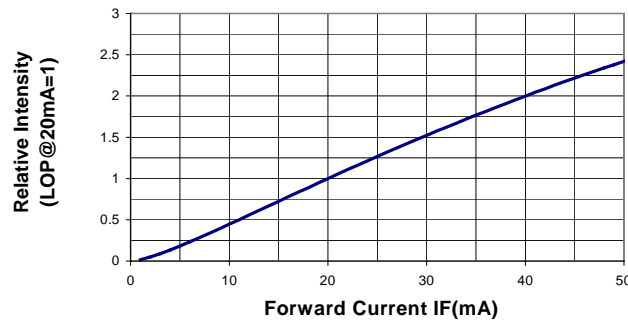

**Beam Pattern**

