



150mA Ultra-Low Dropout Adjustable and Fixed Regulators

Features

- Stable with 2.2µF Low ESR Ceramic Capacitor
Voltage Reference Accuracy of 2%
Wide Operating Range: 4.5V ~ 25V
Quiescent Current in Shutdown of 5µA
Current Limit and Thermal Shutdown
Logic Input Enable Pin
RoHS Compliant halogen-free SOT-89, ESOP-8, J-lead 2021-8, TSOT-23-5 and SOT-23-5 Packages

Description

The APU8850 device is an efficient linear voltage regulator with better than 2% initial voltage accuracy, very low dropout voltage and very low ground current, designed especially for hand-held, battery-powered applications.

The APU8850-3 is available in fixed and adjustable output voltage versions in a small SOT-23-5, TSOT-23-5, J-lead 2021-8, ESOP-8 or SOT-89 package.

Applications

- Laptop, Notebook and Palmtop computers
Battery Powered Equipments
PCMCIA Vcc and Vpp Regulator
Consumer Electronics
High Efficiency Linear Power Supplies

Typical Application

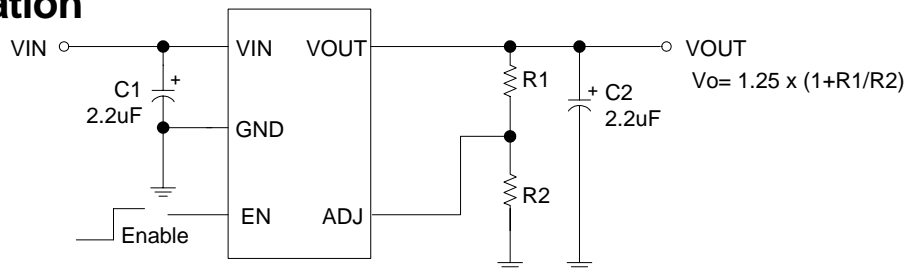

Figure 1 - Typical application of the APU8850-3 adjustable voltage regulator.

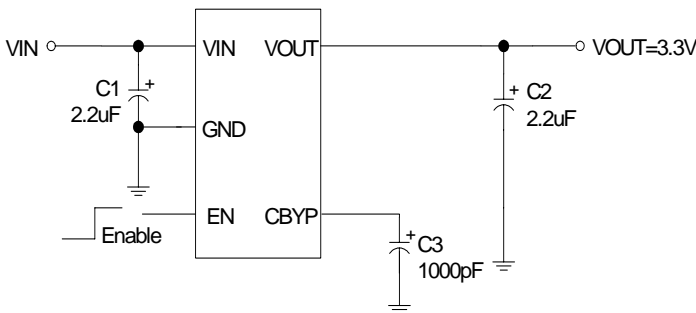

Figure 2 - Typical application of the APU8850-33-3

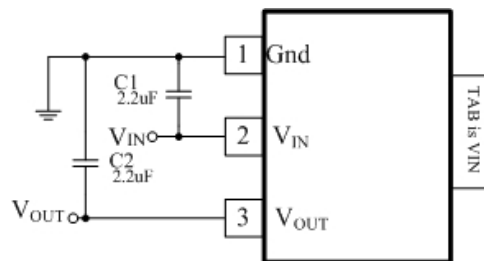

Figure 3 - Typical application of the APU8850-xx-3 in SOT-89

Ordering information

Table with 2 columns: PART NUMBER and OUTPUT VOLTAGE. Rows include APU8850xx-3TR (Adj), APU8850xx-15-3TR (1.5V), APU8850xx-18-3TR (1.8V), APU8850xx-25-3TR (2.5V), APU8850xx-28-3TR (2.8V), APU8850xx-30-3TR (3.0V), APU8850xx-33-3TR (3.3V), and APU8850xx-50-3TR (5.0V).

xx = package code

- Y5: SOT-23-5 TY5: TSOT-23-5
U: J-lead 2021-8
G: SOT-89
MP: ESOP-8

These products are shipped on tape and reel, 3000 pieces per reel (SOT-89 1000pcs/reel). The device is rated MSL3 for moisture sensitivity, and the reel is shipped sealed inside a moisture barrier bag.



## Absolute Maximum Ratings

|  |                |
|--|----------------|
| Input Voltage ( $V_{IN}$ ) .....           | 27V            |
| Enable Input Voltage .....                 | 27V            |
| Storage Temperature Range .....            | -65°C to 150°C |
| Operating Junction Temperature Range ..... | -40°C to 85°C  |

Thermal Resistance Junction to Ambient ( $R_{thja}$ )

|                      |         |
|----------------------|---------|
| SOT-23-5L/TSOT-23-5L | 256°C/W |
| SOT-89               | 300°C/W |
| ESOP-8               | 150°C/W |
| J-lead 2021-8        | 300°C/W |

## Pin Configuration

SOT-23-5L/TSOT-23-5L

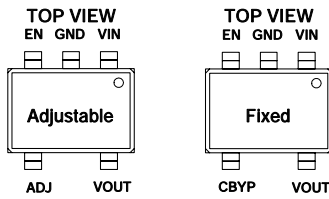

ESOP-8 (\*Adj/Fixed)  
(Top View)

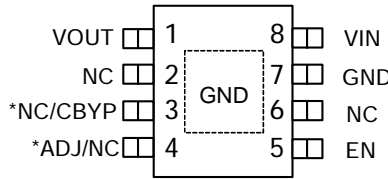

J-lead 2021-8  
(Top View)

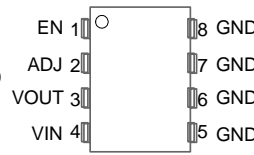

SOT-89  
(Top View)

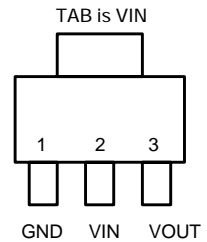

## Electrical Specifications

Unless otherwise specified, these specifications apply over  $C_{IN}=C_O=2.2F$ ,  $I_O=100\mu A$ ,  $V_{IN(MIN)}=4.5V$ ,  $C_{BYP}=470pF$  (for fixed voltage devices),  $V_{EN}=2V$  and  $T_A=25^\circ C$ . Typical values refer to  $T_A=25^\circ C$ . Low duty cycle pulse testing is used which keeps junction and case temperatures equal to the ambient temperature.

| Parameter                            | SYM          | TEST CONDITION   | MIN | TYP  | MAX | UNITS      |
|--------------------------------------|--------------|--|-----|------|-----|------------|
| Reference Voltage                    | $V_O$        |  | -2  | -    | 2   | %          |
| Line Regulation                      | $\Delta V_L$ | $V_O + 2V < V_{IN} < 25V$ , $I_O=1mA$                    | -   | 0.1  | -   | %/V        |
| Load Regulation (Note 1)             | $\Delta V_L$ | $V_{IN}=V_O+2V$  | -   | 0.5  | -   | %          |
| Dropout Voltage (Note 2)             | $V_{DROP}$   | $I_O=100\mu A$   | -   | 1    | -   | V          |
|                                      |              | $I_O=100mA$  | -   | 1.2  | -   |            |
| Ground Current (Note 3)              | $I_Q$        | $V_{EN}=2V$ , $I_O=100\mu A$                             | -   | 250  | -   | $\mu A$    |
| Ground Current-SD Activated          | $I_{Q(SD)}$  | $V_{EN}=0V$ or Open                                      | -   | 1    | -   | $\mu A$    |
| Adjust Pin Current                   | $I_{ADJ}$    | $V_{IN}=4.5V$ , $V_O=V_{ADJ}$                            | -   | 0.1  | -   | $\mu A$    |
| Current Limit                        | $I_{CL}$     |  | 200 | -    | -   | mA         |
| Short Current                        | $I_Z$        | $V_O=0V$   | -   | 175  | -   | mA         |
| Enable Pin Input LO Voltage          | $V_{EN(L)}$  | Regulator OFF  | -   | -    | 0.8 | V          |
| Enable Pin Input HI Voltage          | $V_{EN(H)}$  | Regulator ON   | 2   | -    | -   | V          |
| Enable Pin Input LO Current          |              | $V_{EN(L)}=0V$   | -   | 0.01 | -   | $\mu A$    |
| Enable Pin Input HI Current          |              | $V_{EN(H)}=2V$   | -   | 10   | -   | $\mu A$    |
| Ripple Rejection                     | PSRR         | $C_{BYP}=1nF$ , $C_{OUT}=2.2\mu F$ , $f_{RIPPLE} = 1kHz$ | -   | 70   | -   | dB         |
| Over Temperature Shutdown            |              |  | -   | 150  | -   | $^\circ C$ |
| Over Temperature Shutdown Hysteresis |              |  | -   | 10   | -   | $^\circ C$ |

**Note 1:** Low duty cycle pulse testing with Kelvin connections is required in order to maintain accurate data.

**Note 2:** Dropout voltage is defined as the minimum differential voltage between  $V_{IN}$  and  $V_{OUT}$  required to maintain regulation at  $V_{OUT}$ .

It is measured when the output voltage drops 1% below its nominal value.

**Note 3:** Ground current is the regulator quiescent current plus the pass transistor current. The total current from the supply is the sum of the load current plus the ground pin current.



## Pin Descriptions

| PIN SYMBOL                    | PIN DESCRIPTION   |
|-------------------------------|---|
| VIN                           | The input pin of the regulator. Typically a large storage capacitor is connected from this pin to ground to ensure that the input voltage does not sag below the minimum dropout voltage during the load transient response. This pin must always be higher than VOUT by at least the amount of the dropout voltage and some margin in order for the device to regulate properly. |
| GND                           | Ground pin. This pin must be connected to the lowest potential in the system and all other pins must be at higher potential with respect to this pin.   |
| EN                            | Enable pin. A low signal or left open on this pin shuts down the output. This pin must be tied HI or to VIN for normal operation.   |
| Adj (Adjustable only)         | A resistor divider from this pin to the VOUT pin and ground sets the output voltage.  |
| C <sub>BYP</sub> (Fixed only) | A 470 to 1000pF bypass capacitor connected to this pin reduces the output noise.  |
| VOUT                          | The output of the regulator. A capacitor with a minimum value of 2.2uF and a maximum ESR of 1Ω must be connected from this pin to ground to ensure stability.   |

## Block Diagram

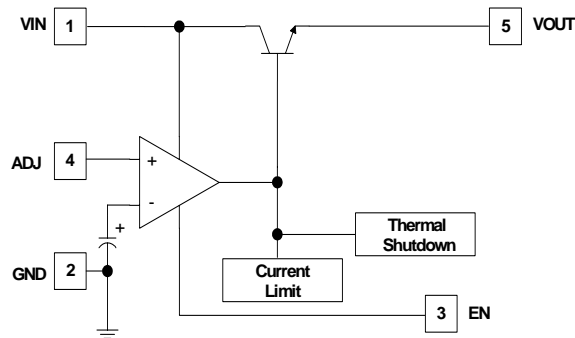

Figure 4 - APU8850Y5 block diagram for adjustable output

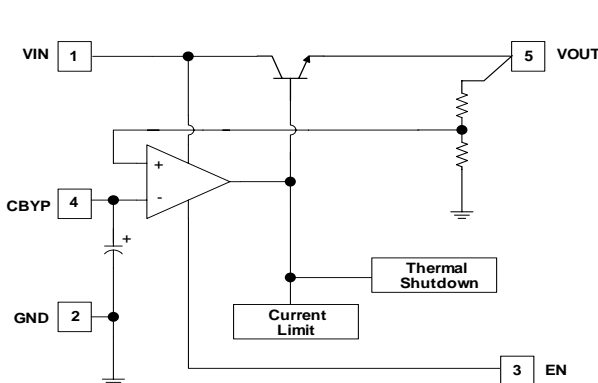

Figure 5 - APU8850Y5 block diagram for fixed output voltage

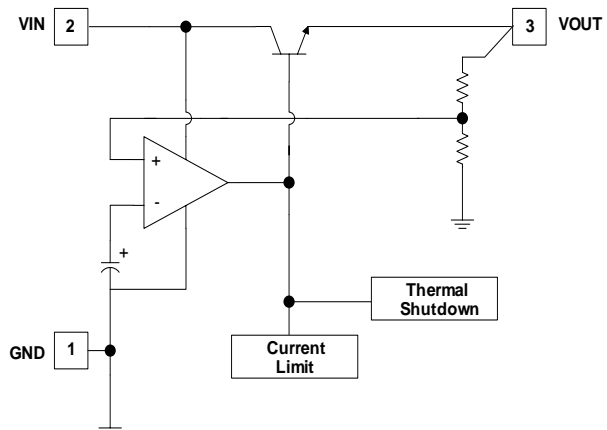

Figure 6 - APU8850G block diagram for fixed output voltage

THIS PRODUCT IS SENSITIVE TO ELECTROSTATIC DISCHARGE, PLEASE HANDLE WITH CAUTION.

USE OF THIS PRODUCT AS A CRITICAL COMPONENT IN LIFE SUPPORT OR OTHER SIMILAR SYSTEMS IS NOT AUTHORIZED.

APEC DOES NOT ASSUME ANY LIABILITY ARISING OUT OF THE APPLICATION OR USE OF ANY PRODUCT OR CIRCUIT DESCRIBED HEREIN; NEITHER DOES IT CONVEY ANY LICENSE UNDER ITS PATENT RIGHTS, NOR THE RIGHTS OF OTHERS.

APEC RESERVES THE RIGHT TO MAKE CHANGES WITHOUT FURTHER NOTICE TO ANY PRODUCTS HEREIN TO IMPROVE RELIABILITY, FUNCTION OR DESIGN.



## Typical Performance Characteristics

VIN=5V, VEN=5V, VOUT=3.3V

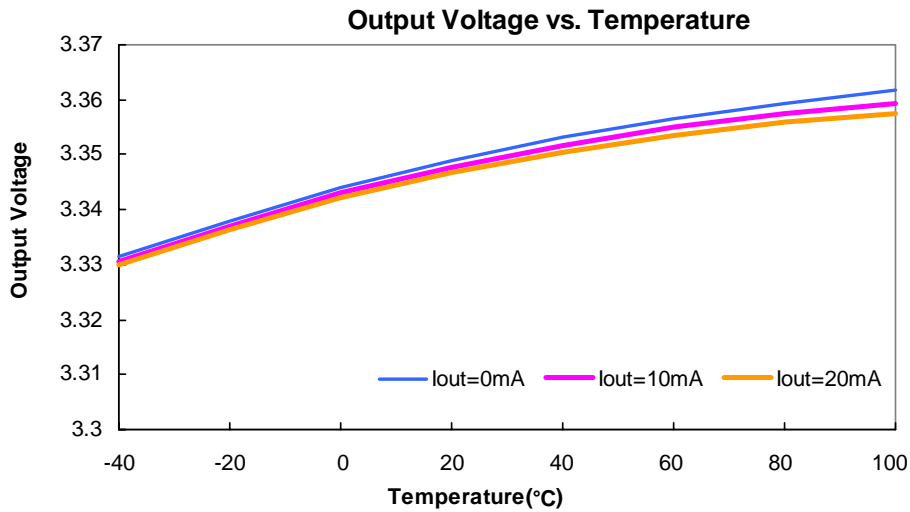

VIN=5V, VEN=5V, VOUT=3.3V

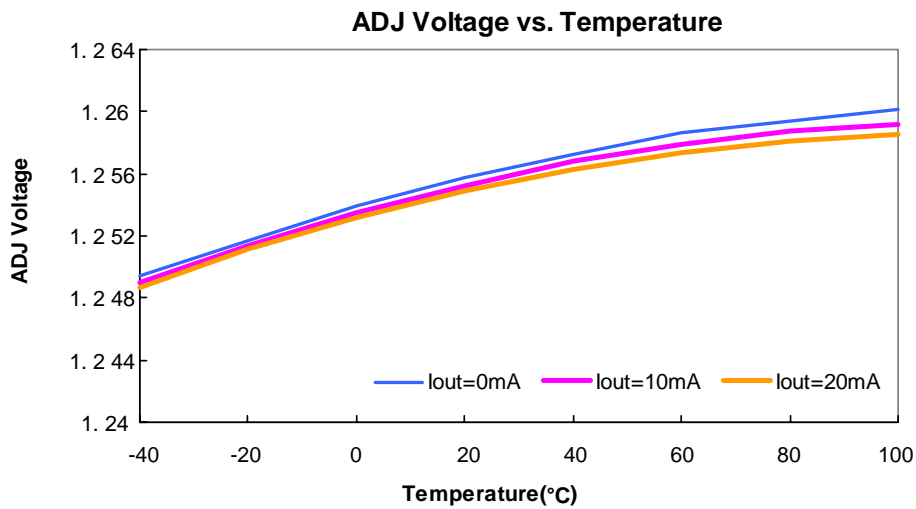

VIN=4.5V, VOUT=3.3V, IOU=10mA~200mA

### Load Transient





## Typical Performance Characteristics (cont.)

Quiescent Current vs. Temperature  
VIN=4.5V, VOUT=3.3V, IOUT=10mA

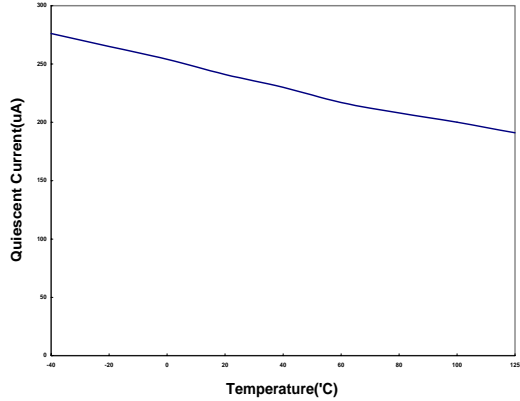

Quiescent Current vs. Input Voltage  
VIN=4.5V~20V, VOUT=3.3V

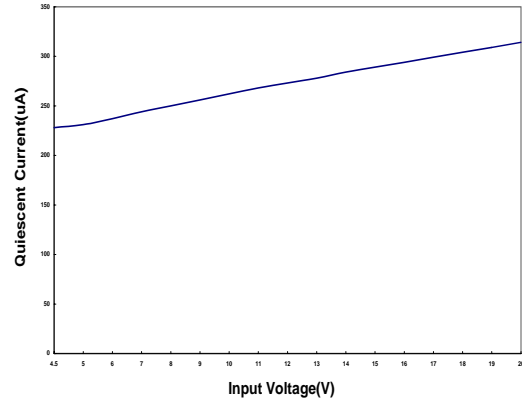

Output Voltage vs. Output Current  
VIN=4.5V, VOUT=3.3V, IOUT=10mA~200mA

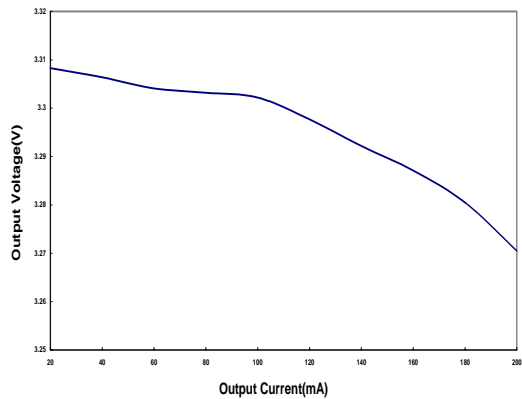

Output Voltage vs. Input Voltage  
VIN=4.5V~20V, VOUT=3.3V

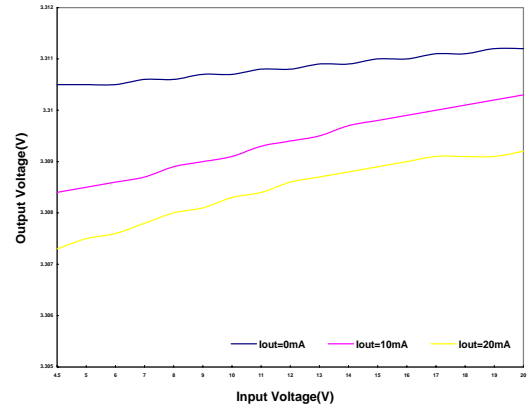

Dropout Voltage vs. Temperature  
VIN=4.5V, VOUT=3.3V

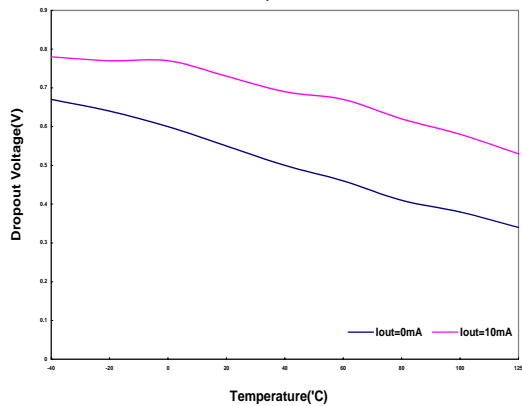

Dropout Voltage vs. Output Current  
VIN=4.5V, VOUT=3.3V, IOUT=10mA~200mA

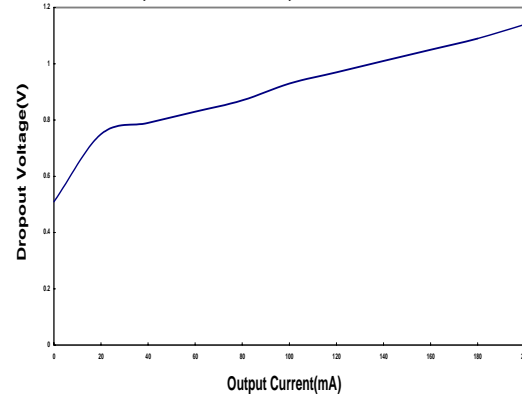



**Package Dimensions: SOT-23-5L**

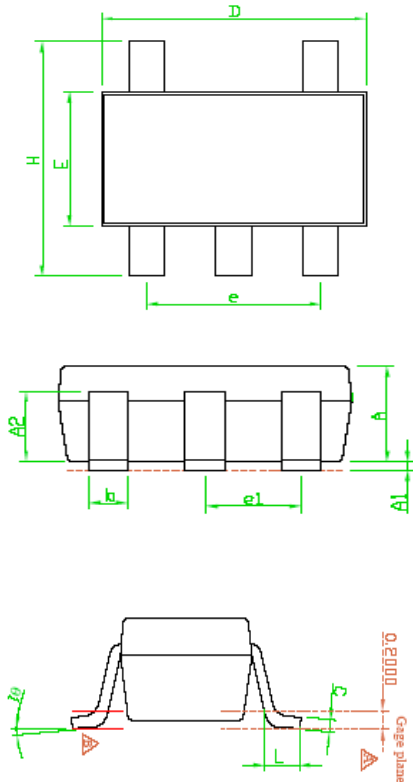

| SYMBOLS | Millimeters |           |      |
|---------|-------------|-----------|------|
|         | MIN         | NOM       | MAX  |
| A       | 1.00        | 1.10      | 1.30 |
| A1      | 0.00        | ---       | 0.10 |
| A2      | 0.70        | 0.80      | 0.90 |
| b       | 0.35        | 0.40      | 0.50 |
| C       | 0.10        | 0.15      | 0.25 |
| D       | 2.70        | 2.90      | 3.10 |
| E       | 1.50        | 1.60      | 1.80 |
| e       | ---         | 1.90(TYP) | ---  |
| H       | 2.60        | 2.80      | 3.00 |
| L       | 0.37        | ---       | ---  |
| θ1      | 1°          | 5°        | 9°   |
| e2      | ---         | 0.95(TYP) | ---  |

Note 1: Package body sizes exclude mold flash protrusions or gate burrs.

Note 2: Tolerance  $\pm 0.1000$  mm (4mil) unless otherwise specified.

Note 3: Coplanarity:0.1000 mm

Note 4: Dimension L is measured in gage plane.

**Marking Information**

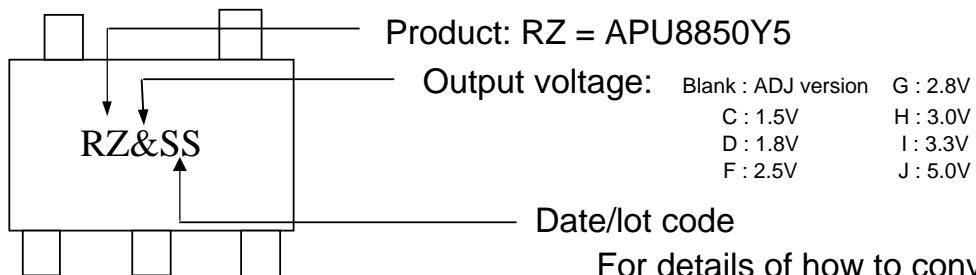

For details of how to convert this to standard YYWW date code format, please contact us directly.



**Package Dimensions: J-lead 2021-8**

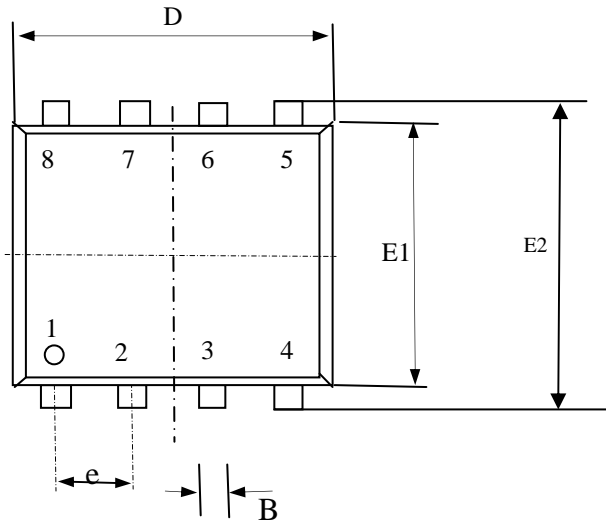

| SYMBOLS  | Millimeters |      |      |
|----------|-------------|------|------|
|          | MIN         | NOM  | MAX  |
| E        | 1.80        | 2.10 | 2.40 |
| E1       | 1.65        | 1.75 | 1.85 |
| E2       | 2.00        | 2.20 | 2.40 |
| L        | 0.35        | 0.45 | 0.55 |
| A        | ---         | ---  | 1.10 |
|          | 0.00        | ---  | 0.10 |
| A2       | 0.70        | 0.90 | 1.00 |
| D        | 1.80        | 2.00 | 2.20 |
| B        | 0.15        | --   | 0.35 |
| C        | 0.10        | 0.15 | 0.20 |
| $\theta$ | 0°          | 4°   | 8°   |
| e        | 0.5bsc      |      |      |

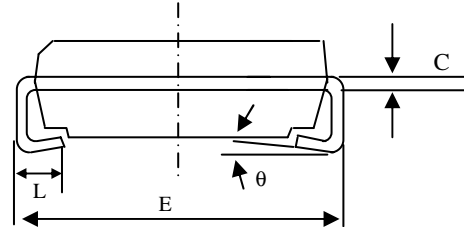
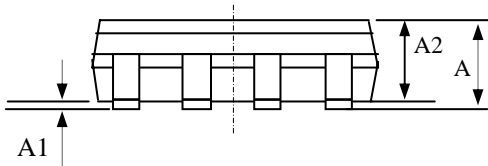

1. All dimensions are in millimeters.
2. Dimensions do not include mold protrusions.

**Marking Information**

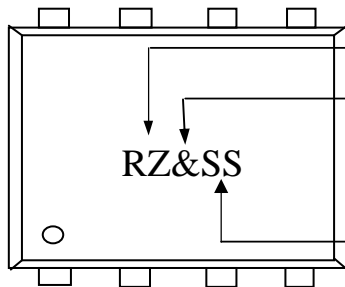

Product: RZ = APU8850U

Output voltage: Blank : ADJ version G : 2.8V  
 C : 1.5V H : 3.0V  
 D : 1.8V I : 3.3V  
 E : 2.5V J : 5.0V

Date/lot code

For details of how to convert this to standard YYWW date code format, please contact us directly.



**Package Dimensions: SOT-89**

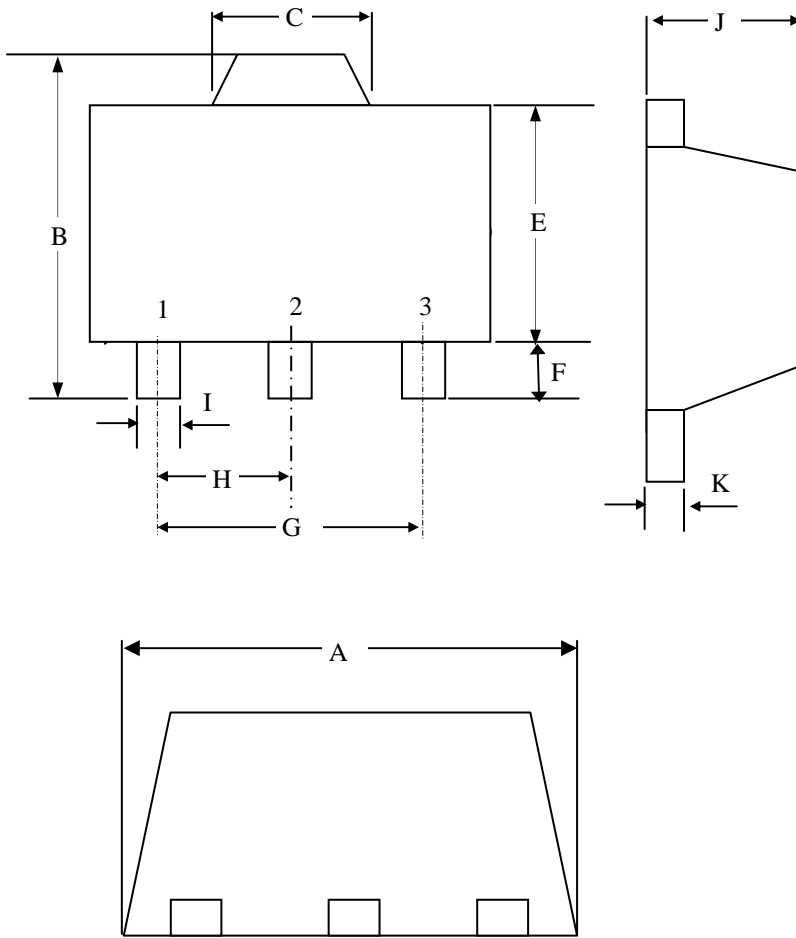

| SYMBOLS | Millimeters |      |      |
|---------|-------------|------|------|
|         | MIN         | NOM  | MAX  |
| A       | 4.40        | -    | 4.60 |
| B       | 4.05        | -    | 4.25 |
| C       | 1.40        | -    | 1.75 |
| E       | 2.40        | -    | 2.60 |
| F       | 0.89        | -    | 1.20 |
| I       | 0.35        | -    | 0.55 |
| H       | ----        | 1.50 | ---- |
| G       | ----        | 3.00 | ---- |
| J       | 1.40        | -    | 1.60 |
| K       | 0.35        | -    | 0.43 |

1. All dimensions are in millimeters.
2. Dimensions do not include mold protrusions.

**Marking Information**

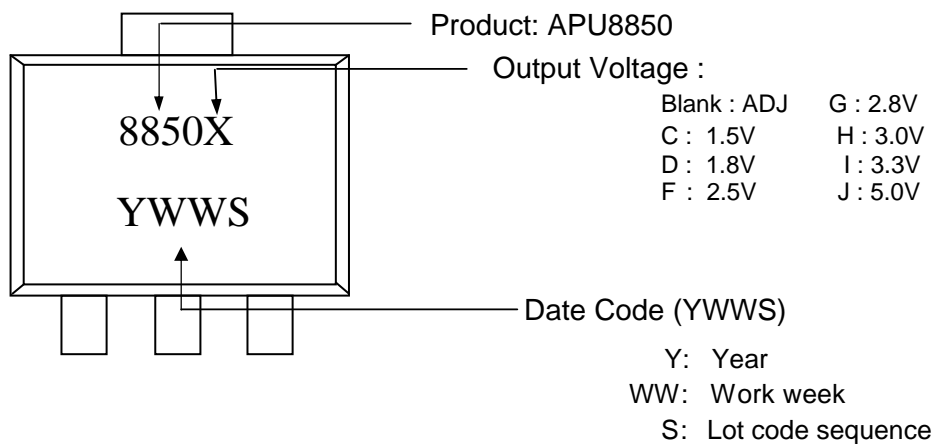





**Package Dimensions: ESOP-8**

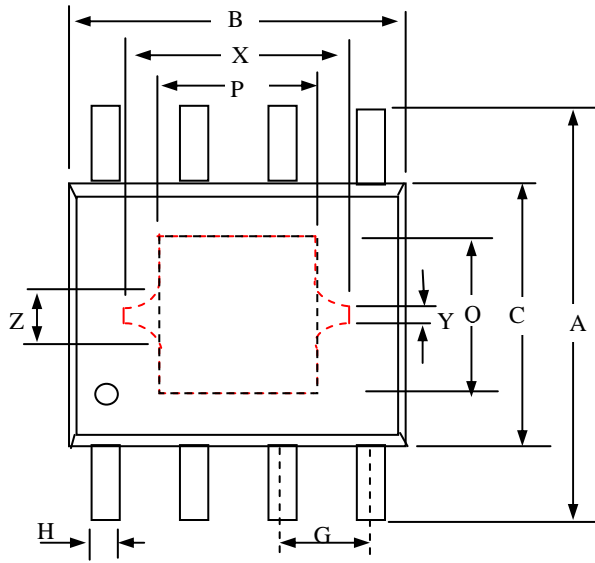

| Millimeters |           |      |      |
|-------------|-----------|------|------|
| SYMBOLS     | MIN       | NOM  | MAX  |
| A           | 5.70      | 5.95 | 6.20 |
| B           | 4.80      | 4.95 | 5.10 |
| C           | 3.80      | 3.90 | 4.00 |
| D           | 0°        | 4°   | 8°   |
| E           | 0.40      | 0.84 | 1.27 |
| F           | 0.19      | 0.23 | 0.26 |
| M           | 0.00      | 0.13 | 0.25 |
| H           | 0.32      | 0.42 | 0.51 |
| L           | 1.35      | 1.56 | 1.76 |
| G           | 1.27 TYP. |      |      |
| P           | 1.65      | 2.13 | 2.60 |
| Q           | 1.65      | 2.13 | 2.60 |
| X           | 3.25 REF. |      |      |
| Y           | 0.20 REF. |      |      |
| Z           | 0.47 REF. |      |      |

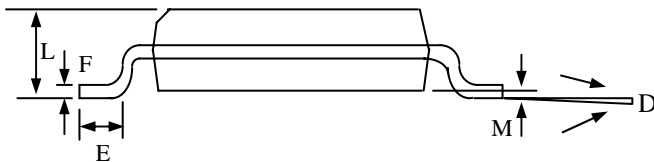

1. All dimensions are in millimeters.
2. Dimensions do not include mold protrusions.

**Marking Information**

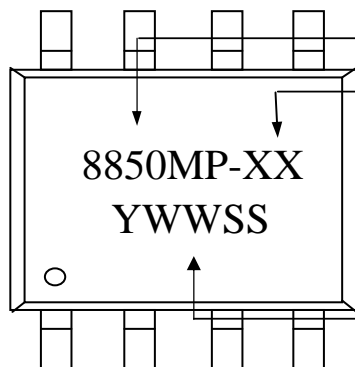

Product: APU8850MP

Output Voltage :

|             |           |
|-------------|-----------|
| Blank : ADJ | 28 : 2.8V |
| 15 : 1.5V   | 30 : 3.0V |
| 18 : 1.8V   | 33 : 3.3V |
| 25 : 2.5V   | 50 : 5.0V |

Date/lot Code (YWWSS)

Y: Year  
WW: Work week  
SS: Lot code sequence